

Type RC

Customised position of hole centre, drilled by Lindapter to suit the application. For flanges of 10mm thickness or greater, either parallel or tapered up to 5°.

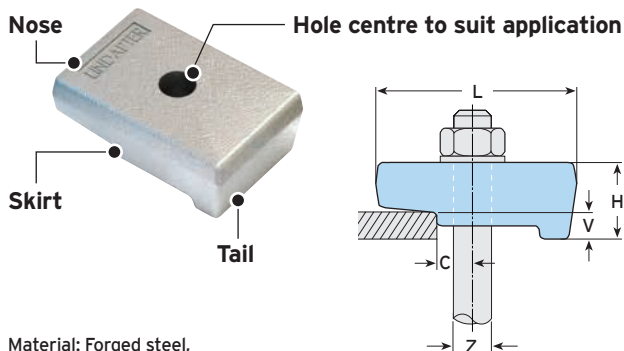

Material: Forged steel, corrosion protection as required.

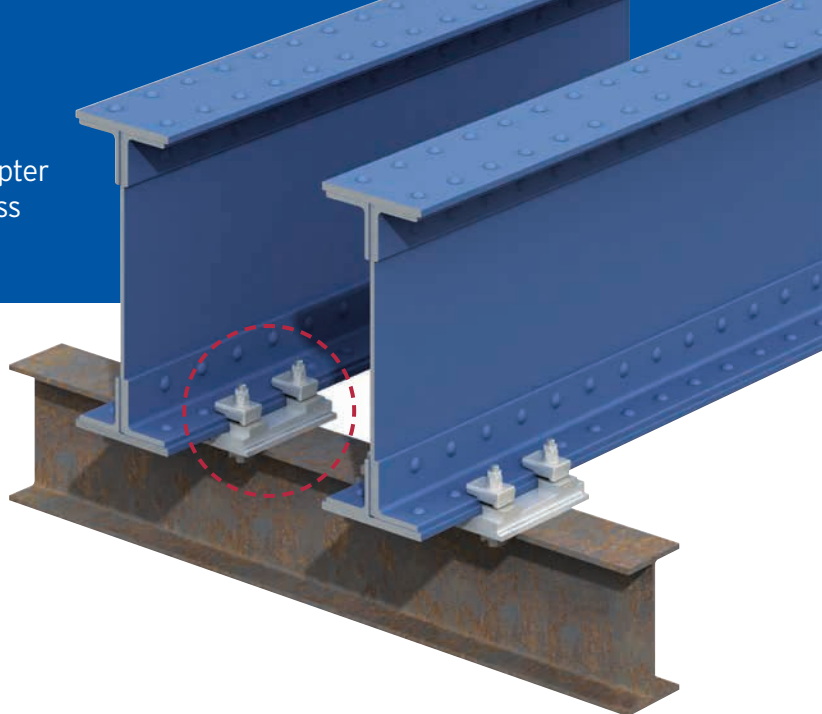

Product Code	Bolt 8.8 Z	Safe Working Loads Tensile / 1 Bolt (FOS 5:1)	Tightening Torque*	Tail Length V	Dimensions			
					C	L	H	Width
RCS12	M12	2.6	69	10	6.5 - 26.5	76	29	50
RCS16	M16	4.0	147	10	9 - 24	76	29	50
RCS20	M20	9.6	285	10	11 - 22	76	29	50
RCS24	M24	12.3	491	10	13 - 20	76	29	50

* Torque figures based on bolts / setscrews in an unlubricated condition. For further information on lubricated fasteners see page 70.

➔ Contact Lindapter to ensure suitability of the component for application.

Type F9

A flange clamp for connecting parallel running steel sections with flanges of the same width. Can be used with bolts or threaded rod.

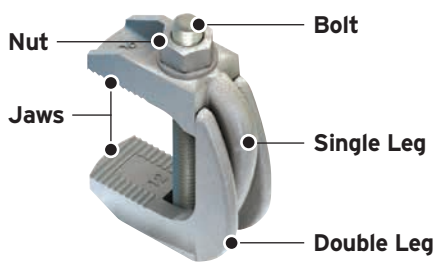

Material: Malleable iron, zinc plated or hot dip galvanised.



Product Code		Bolt 8.8 Z	Safe Working Loads Tensile / 1 Bolt (FOS 5:1)	Tightening Torque*	Clamping Range V	Dimensions			
with Bolt	without Bolt					Y	J	X	Width
F910NC	F910NB	M10	2.0	20	19 - 42	25	13	19	24
F912NC	F912NB	M12	2.8	39	26 - 60	35	17	24	30
F916NC	F916NB	M16	5.6	93	29 - 69	43	21	28	35
F920NC	F920NB	M20	8.4	177	32 - 82	51	25	35	44
F924NCHDG ¹⁾	F924NBHDG ¹⁾	M24	14.0	235	45 - 95	76	38	55	63

¹⁾ Available in hot dip galvanised only.

* Torque figures based on bolts / setscrews in an unlubricated condition. For further information on lubricated fasteners see page 70.

➔ Not suitable for tapered flanges.

CE For Characteristic Resistances when designing a connection to Eurocode 3, please refer to DoP No.010 on the website www.Lindapter.com