

# Type F3

An FM approved, high strength flange clamp with a large clamping range. Compatible with drop rods and J bolts.

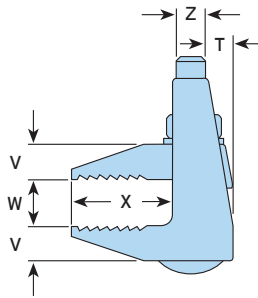

For heavier loads or wider clamping range, please see the Type F9 on page 24.

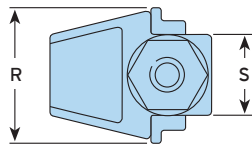
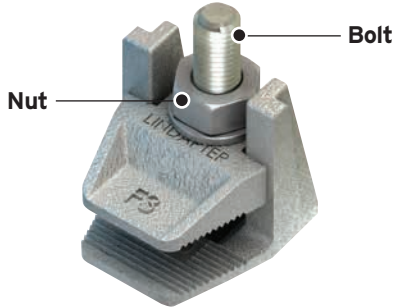
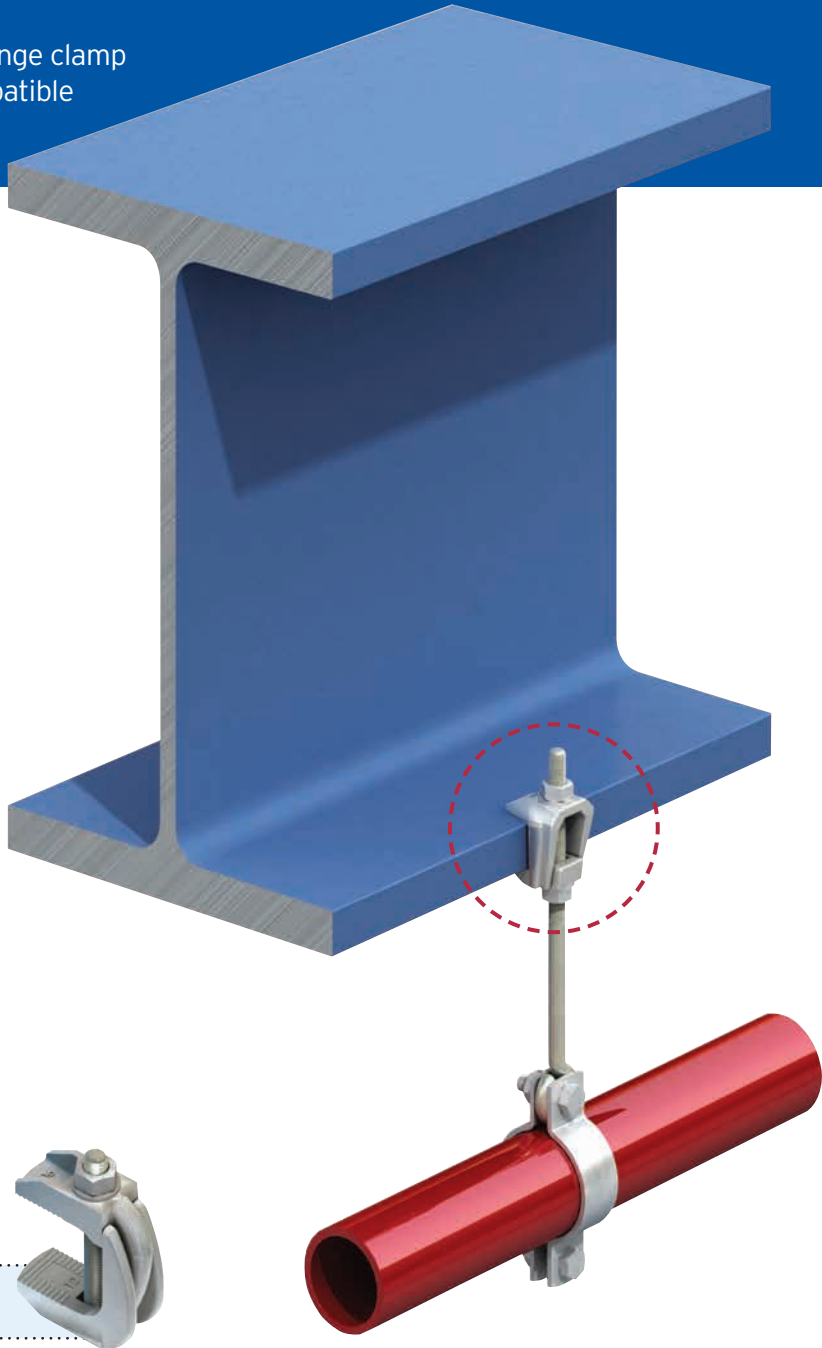

Material: Malleable iron, hot dip galvanised.

Product Code		Bolt 4.6 Z	Safe Working Load (FOS 4:1) Tensile kN	Clamping Range W mm	Tightening Torque* Nm	Dimensions				
With Bolt	Without Bolt					S	T	V	X	Width R
F308NC	F308NB	M8	0.9	2 - 25	6	19	6	8	20	33
F310NC	F310NB	M10	1.2	2 - 30	20	22	7	10	25	38
F312NC	F312NB	M12	2.0	2 - 40	39	29	9	12	35	49
F316NC	F316NB	M16	4.0	3 - 55	93	36	12	16	46	60
F320NC	F320NB	M20	6.0	5 - 70	177	44	15	19	55	76

\* Torque figures based on bolts / setscrews in an unlubricated condition. For further information on lubricated fasteners see page 70.

➤ For parallel flanges only. Supplied with or without bolt.